

IGBT Modules

V _{CES}	1200V
I _C	150A

Applications

- Inverter for motor drive
- AC and DC servo drive amplifier
- UPS (Uninterruptible Power Supplies)
- Soft switching welding machine

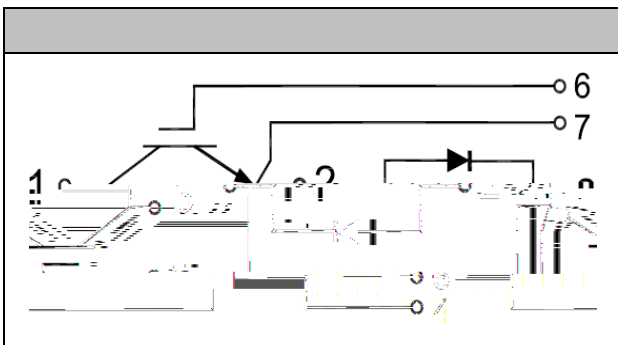

Features

- Low V_{ce(sat)} with Trench technology
- V_{ce(sat)} with positive temperature coefficient
- High short circuit capability(10 μ s)
- Including ultra fast & soft recovery anti-parallel FWD
- Low inductance
- Maximum junction temperature 175

● IGBT

Absolute Maximum Ratings

Parameter	Symbol	Conditions	Value	Unit
Collector-Emitter Voltage	V _{CES}	V _{GE} =0V, I _C =1mA, T _{vj} =25	1200	V
Continuous Collector Current	I _C	T _C =100	150	A
Repetitive Peak Collector Current	I _{CRM}	t _p =1ms	300	A
Gate-Emitter Voltage	V _{GES}	T _{vj} =25	20	V
Total Power Dissipation	P _{tot}	T _C =25 T _{vjmax} =175	833	W

Characteristic values

Parameter	Symbol	Conditions	Value			Unit	
			Min.	Typ.	Max.		
Gate-emitter Threshold Voltage	$V_{GE(th)}$	$V_{GE}=V_{CE}, I_C=4mA, T_{vj}=25$	5.0	6.2	7.0	V	
Collector-Emitter Cut-off Current	I_{CES}	$V_{CE}=1200V, V_{GE}=0V, T_{vj}=25$			1.0	mA	
Collector-Emitter Saturation Voltage	$V_{CE(sat)}$	$I_C=150A, V_{GE}=15V, T_{vj}=25$		1.85		V	
		$I_C=150A, V_{GE}=15V, T_{vj}=125$		2.05			
Gate Charge	Q_G			1.56		uC	
Input Capacitance	C_{ies}	$V_{CE}=25V, V_{GE}=0V,$ $f=1MHz, T_{vj}=25$		11.0		nF	
Reverse Transfer Capacitance	C_{res}			0.5		nF	
Gate-Emitter leakage current	I_{GES}	$V_{CE}=0V, V_{GE}=20V, T_{vj}=25$			400	nA	
Turn-on Delay Time	$t_{d(on)}$	$I_C=150A$ $V_{CE}=600V$ $V_{GE}=\pm 15V$ $R_G=4.7$ $T_{vj}=25$		347		ns	
Rise Time	t_r			75		ns	
Turn-off Delay Time	$t_{d(off)}$			375		ns	
Fall Time	t_f			181		ns	
Energy Dissipation During Turn-on Time	E_{on}			8.9		mJ	
Energy Dissipation During Turn-off Time	E_{off}			9.3		mJ	
Turn-on Delay Time	$t_{d(on)}$		$I_C=150A$ $V_{CE}=600V$ $V_{GE}=\pm 15V$ $R_G=4.7$ $T_{vj}=125$		352		ns
Rise Time	t_r				81		ns
Turn-off Delay Time	$t_{d(off)}$				301		ns
Fall Time	t_f				327		ns
Energy Dissipation During Turn-on Time	E_{on}			11.9		mJ	
Energy Dissipation During Turn-off Time	E_{off}			16.0		mJ	
SC Data	I_{sc}	$T_p=10\mu s, V_{GE}=15V,$ $T_{vj}=150, V_{cc}=900V,$ $V_{CEM}=1200V$			890		A

● Diode
Absolute Maximum Ratings

Parameter	Symbol	Conditions	Value	Unit
Repetitive Peak Reverse Voltage	V_{RRM}	$T_{vj}=25$	1200	V
Continuous DC Forward Current	I_F		150	A
Repetitive Peak Forward Current	I_{FRM}	$t_p=1\text{ms}$	300	A

Characteristic values

Parameter	Symbol	Conditions	Value			Unit
			Min.	Typ.	Max.	
Forward Voltage	V_F	$I_F=150\text{A}, T_{vj}=25$		1.80	2.00	V
		$I_F=150\text{A}, T_{vj}=125$		1.85		
Recovered Charge	Q_{rr}	$I_F = 150\text{ A}$		14.0		μC
Peak Reverse Recovery Current	I_{rr}	$V_R=600\text{V}$ $-di_F/dt = 2250\text{A}/\mu\text{s}$		143		A
Reverse Recovery Energy	E_{rec}	$T_{vj}=25$		9.5		mJ
Recovered Charge	Q_{rr}	$I_F = 150\text{ A}$		18.5		μC
Peak Reverse Recovery Current	I_{rr}	$V_R=600\text{V}$ $-di_F/dt = 2250\text{A}/\mu\text{s}$		179		A
Reverse Recovery Energy	E_{rec}	$T_{vj}=125$		17.5		mJ

● Module Characteristics
 $T_c=25^{\circ}\text{C}$ unless otherwise specified

Parameter	Symbol	Conditions	Value			Unit
			Min.	Typ.	Max.	
Isolation voltage	V_{isol}	$t=1\text{min}, f=50\text{Hz}$	2500			V
Maximum Junction Temperature	T_{jmax}				175	
Operating Junction Temperature	T_{vjop}		-40		150	
Storage Temperature	T_{stg}		-40		125	
Thermal Resistance Junction-to Case	R_{JC}	per IGBT			0.18	K/W
		per Diode			0.31	
Thermal Resistance Case-to Sink	R_{CS}	Conductive grease applied		0.035		K/W
Module Electrodes Torque	M_t	Recommended(M6)	3.0		5.0	N·m
Module-to-Sink Torque	M_s	Recommended(M6)	3.0		5.0	N·m
Weight of Module	G			315		g

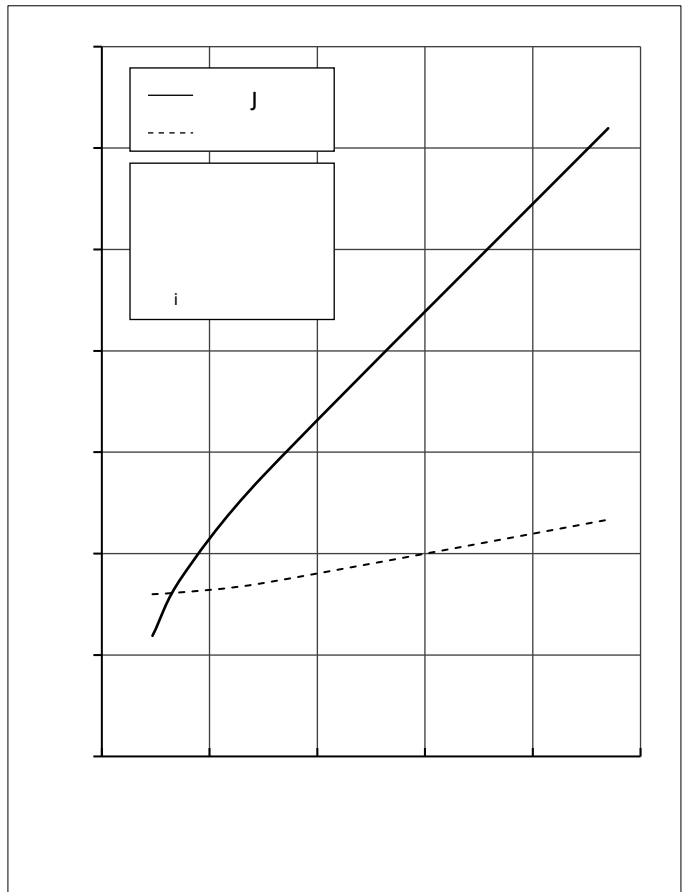
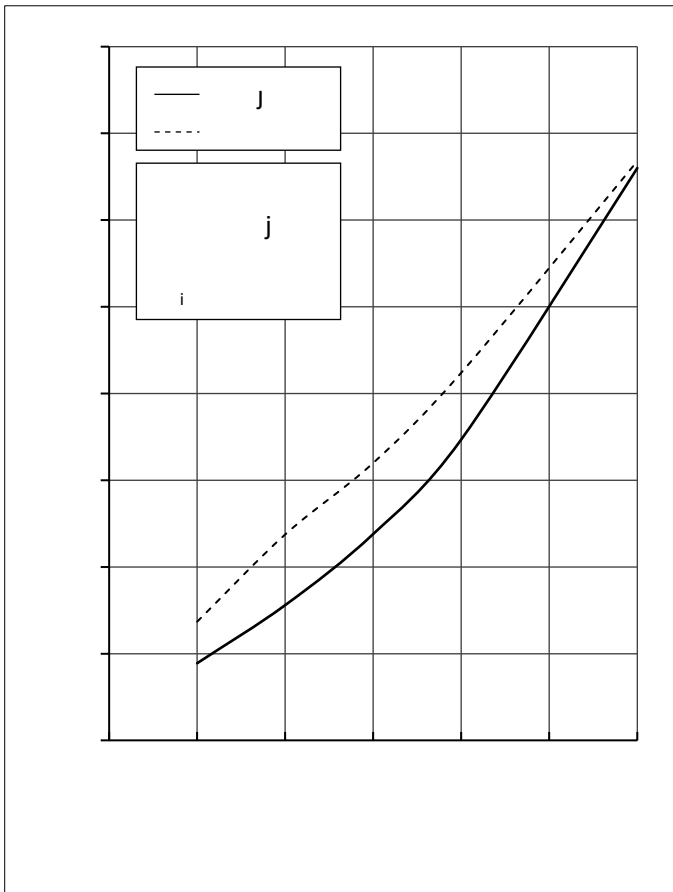
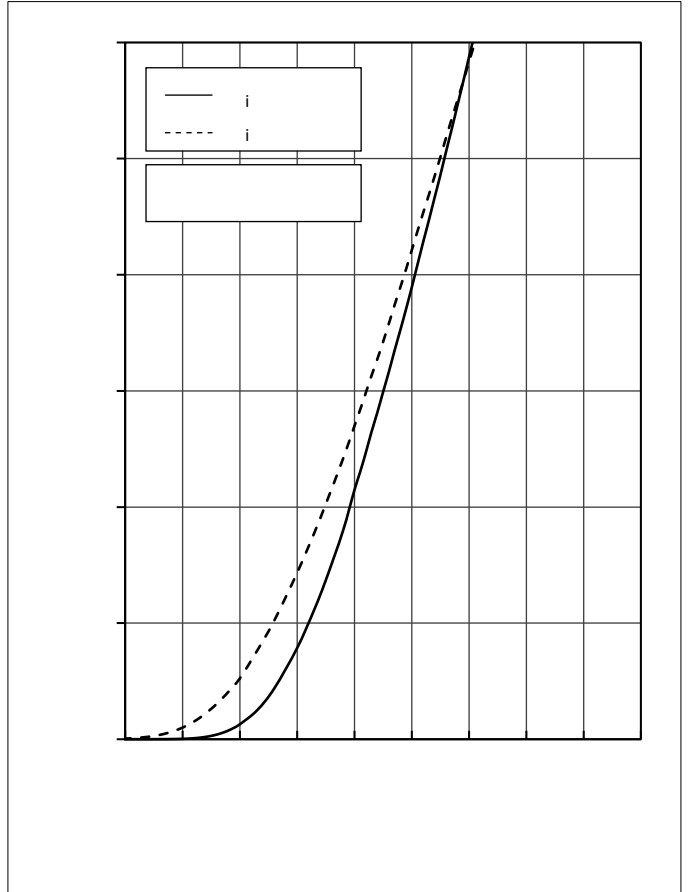
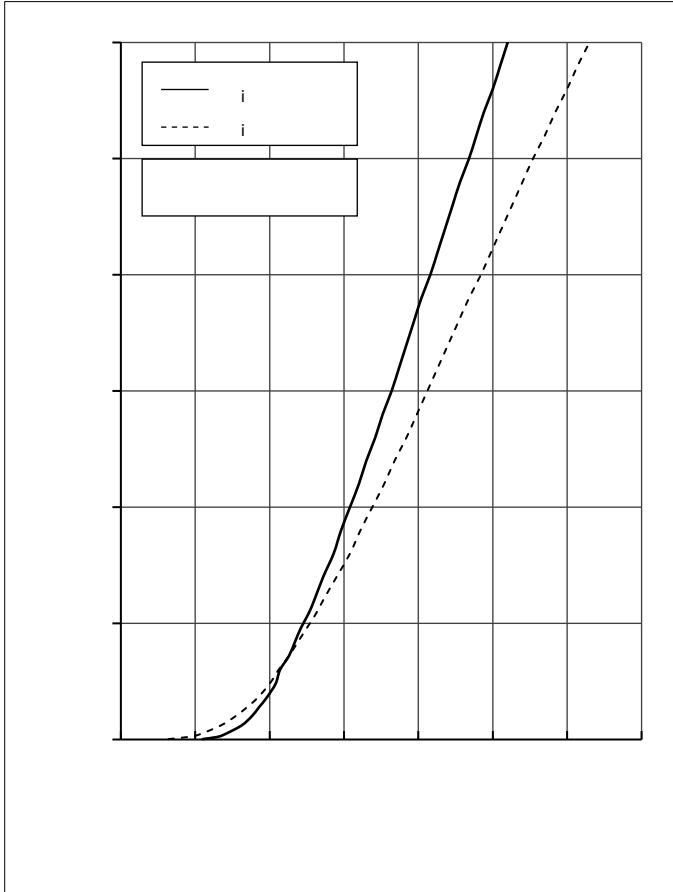

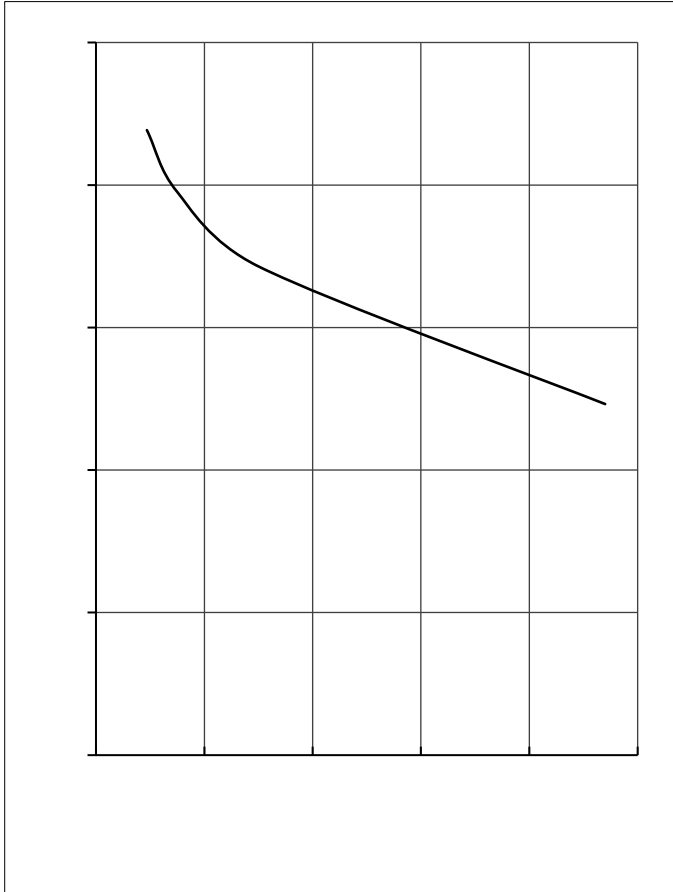

● **Circuit Diagram**

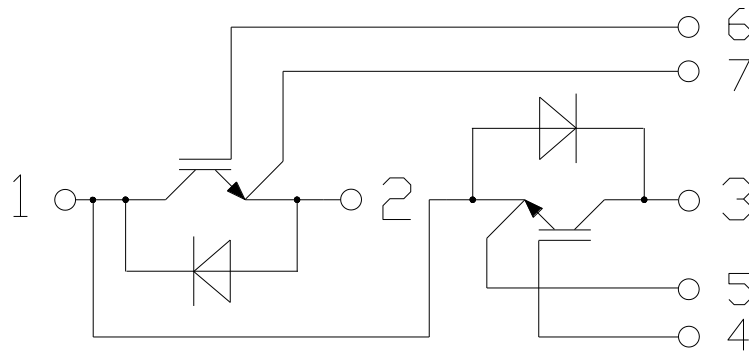

● **Package Outline Information**

Dimensions in Millimeters

