

Dual High Voltage Schottky Rectifier

●Features:

-
-
-
-

●Application:

-
-

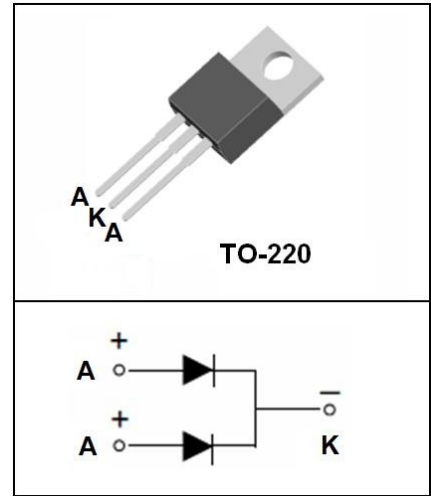

Absolute Maximum Ratings(2 °)

Symbol	Parameter	Value	Unit
		100	
		100	
()	, 120°C	10()	
	, .3	100	
		1 0	°
		- +1 0	°

Thermal Characteristics(2 °)

Symbol	Parameter	Max	Unit
	,	2.	° /
	,	10	° /

Electrical Characteristics(2 °)

Symbol	Parameter	Test Conditons	Min	Max	Unit
--------	-----------	----------------	-----	-----	------

Typical Performance Characteristics

Figure 1. Forward Current Characteristics

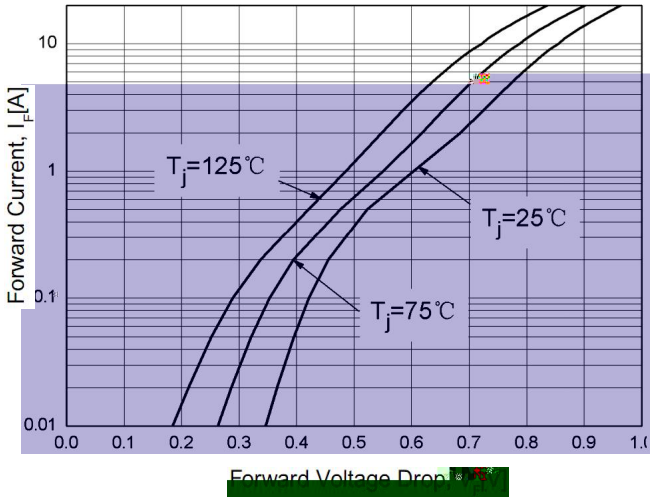

Figure 2. Reverse Leakage Current

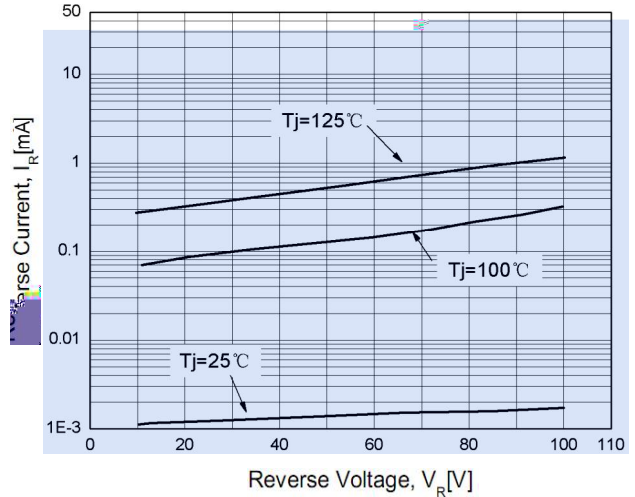

Figure 3. Junction Capacitance

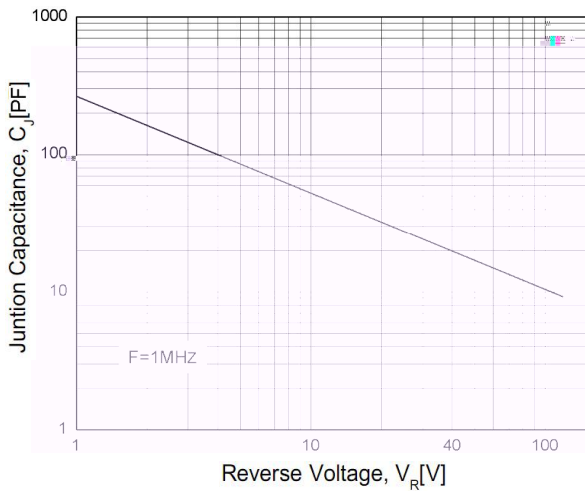
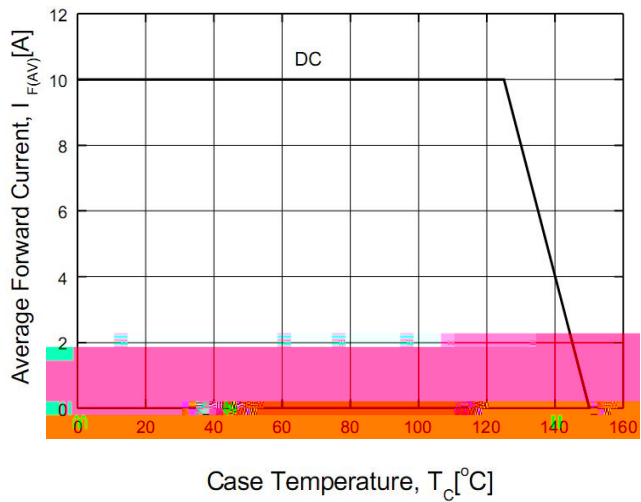

Figure 4. Power Derating



TO-220 MECHANICAL DATA

	.00	. 0		. 0		10. 0
	1.1	1.			2.	
1	0. 0	1. 0		1.10		1. 0
1	0.	0.		12. 0		1 . 0
	0.30	0. 0	1	2. 0	3. 0	3. 0
	1 . 0	1 . 0		2. 0		3.10
1	. 0	. 0	1	2.00		3.00
			ϕ	3. 0		.00

